



SHOP PRESS ASSEMBLY INSTRUCTIONS



CP403 - 40 TON ELECTRIC PRODUCTION PRESS

CP405 - 50 TON ELECTRIC PRODUCTION PRESS WITH WINCH

PRESS SPECIFICATIONS

Arcan Model No.	A	B	C	D	E	F	G	H	I	J	K	L
CP403	74"	32"	29.75"	12"	8.25"	1.25"	1 HP Pendant Remote	9.5'/14 AWG	Emerson 115V/13.2 AMPS	N	N	Y(2)
CP405	74"	35"	29.75"	13"	8"	1.25"	2 HP Pendant Remote	9.5'/14 AWG	Emerson 115V/13.2 AMPS	Y	N	Y(2)

- A - Total Height
- B - Inside Width
- C - Press Feet Length
- D - Bed Width
- E - Stroke (Ram Travel Distance From Fully Retracted Position To Fully Extended Position)
- F - Pin Diameter
- G - Motor Control
- H - Power Cord (Length/Type)
- I - Mfr/Volts/Amps (Electric Motor)
- J - Pb Winch
- K - Sliding Head
- L - Press Plates Included

P.O. Box 58

Travelers Rest, SC 29690

Phone: (800) 879-7316

Fax: (864) 834-0073

SAFETY INFORMATION

WARNING

This symbol alerts you to the possibility of serious injury or death if instructions are not followed.

CAUTION

This symbol alerts you to the possibility of damage to or destruction of equipment if instructions are not followed.

WARNING

Failure to heed these warnings may result in loss of load, damage to the press and/or failure resulting in property damage, personal or fatal injury. This operating manual contains important details concerning the safe operation of this tool. The user must read and understand these details before any use of the tool. This manual must be retained for future reference.

- Read, study, and understand all instruction manuals packed with this press before operating.
- Always wear safety goggles.
- Parts being pressed may splinter, shatter, or be ejected from the press at a dangerous rate of speed. Because of the variety of press applications, it is your responsibility to always use adequate guards and wear eye protection and heavy protective clothing when operating the press.
- Visual inspection should be made before each use of the press, checking for signs of cracked welds, bent bed pins, loose or missing bolts, leaks, or any other structural damage.
- Do not go near leaks. High pressure oil can puncture skin and cause serious injury, gangrene, or death. If injured, seek emergency medical help. Immediate surgery is required to remove oil.
- Keep hands and fingers out of the press and away from parts that may shift and pinch. Do not stand in front of work area when load is applied.
- Always use an accurate pressure gauge to measure pressing force.
- Do not exceed the rated capacity of this press.
- Never tamper with hydraulic system pressure settings.
- Do not substitute bolts, pins or any part of the components. Use only genuine factory replacement parts.
- Always center load on ram plunger. Offset loads can damage ram and may cause load to eject at a dangerous rate of speed.
- Remove all loads from press bed before attempting to adjust bed height. Beware of possibility of falling bed.
- Press only on loads supported by press bed and included press plates. Do not support loads on floor or press frame.
- When using any accessories such as arbor plates, be certain they are centered on press bed and are in full contact with press bed.
- Before applying load, be certain all press bed supporting pins are fully engaged.
- Always use a bearing shield when pressing bearings. Use caution when positioning work to be pressed to ensure that the item that is to be pressed cannot be dislodged or broken during press work. This may result in the item being ejected from the press at a dangerous rate of speed.
- Release hydraulic pressure before loosening any fittings.
- Maintain proper hydraulic fluid levels.
- Do not make any alterations to the press.

OWNER/USER RESPONSIBILITY

The owner and/or user must have an understanding of the manufacturer's operating instructions and warnings before using this press. Personnel involved in the use and operation of equipment must be careful, competent, trained, and qualified in the safe operation of the equipment and its proper use when servicing motor vehicles and their components. Warning information should be emphasized and understood.

If the operator is not fluent in English, the manufacturer's instructions and warnings must be read to and discussed with the operator in the operator's native language by the purchaser/owner, making sure that the operator comprehends its contents.

Owner and/or user must study and maintain for future reference the manufacturer's instructions. Owner and/or user is responsible for keeping all warning labels and instruction manuals legible and intact. Replacement labels and literature are available from the manufacturers.

INSPECTION

Visual inspection of the shop press should be made before each use of the press, checking for damaged, loose or missing parts. Each press must be inspected by a manufacturer's repair facility immediately if subjected to an abnormal load or shock. Any press which appears to be damaged in any way, is found to be badly worn, or operates abnormally must be removed from service until necessary repairs are made by a manufacturer's authorized repair facility. It is recommended that an annual inspection of the press be made by a manufacturer's authorized repair facility and that any defective parts, decals or warning labels be replaced with manufacturer's specified parts. A list of authorized repair facilities is available from the manufacturer.

SAFETY INSTRUCTIONS

- CHECK YOUR LOCAL, STATE AND FEDERAL REGULATIONS REGARDING THE SAFE USE OF THIS EQUIPMENT.
- Your safety is a top priority. Please handle equipment with care.
- Fully retract unit and remove all items from the press bed frame.
- Support the press bed and remove the pins.
- Raise or lower bed to desired height and reinstall press pins. Be certain pins are fully engaged in the parallel flanges of the upright columns.
- Position press on a flat, level, hard surface, preferably concrete. Make sure all nuts and bolts are tight.
- Clear the area of bystanders, especially small children, before using.
- Set the press bed to the required height. The press is most effective when the work piece is located 1 inch below the ram's retracted position. The compression stroke can include the entire 5 inch working range.
- The press is designed to exert a force on anything which is positioned beneath its ram. The work piece can be ejected from under the ram at a high rate of speed and can injure someone.
- Pressing Bearings: It is essential that you use the bearing shield when pressing bearings are on or off.

OPERATION

1. Press beds are adjustable up and down to fully take advantage of available ram travel and numerous work pieces.
2. Slowly open release valve on power unit. With the power unit in its stored position, remove all items from the press bed.
3. Be sure press bed is supported properly and remove press bed pins.
4. Raise or lower press bed to desired height, and reinstall press bed pins. Be certain pins are completely through both sides of frame, as these pins are the major support mechanism for the bed.

We want to know if you have any problems with our products. If you are missing any parts or find any damage, call Arcan directly, and we will remedy the situation. Please do not call the store where you purchased this product.

Phone: (800) 879-7316
Email: arcanusa@bellsouth.net

PARTS LIST

ESTIMATED ASSEMBLY TIME: 45 MINUTES

Press Frame - 1

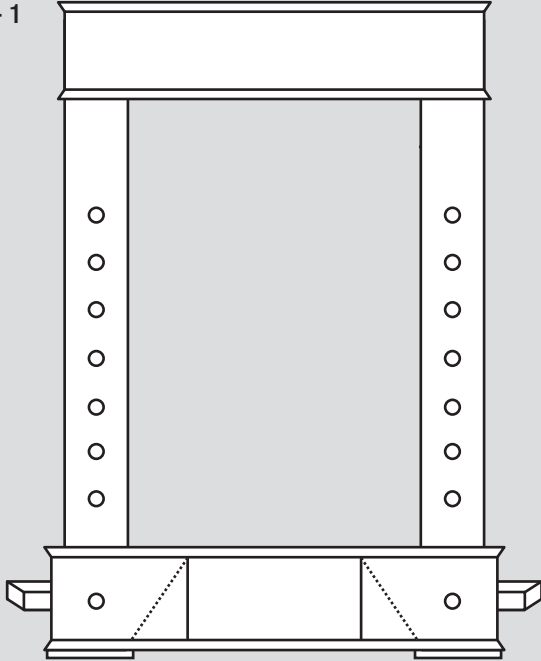

Pump and Ram Assembly - 1

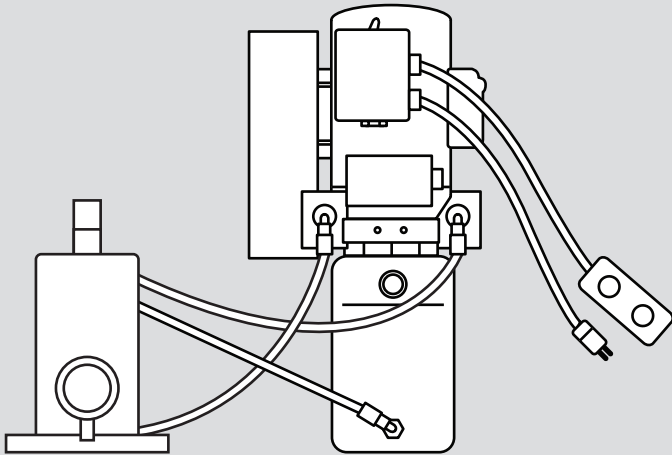

1/2"-13 x 1-1/8" Hex Head Bolts - 2
For Pump Assembly



1/2" Nuts - 2
For Pump Assembly



1/2"-13 x 3/4" Hex Head Bolts - 4

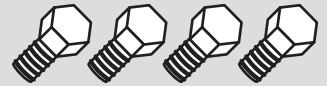

Washers - 6



Air Breather Cap - 1

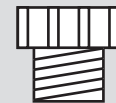

1-1/4" x 14" Press Pins - 4

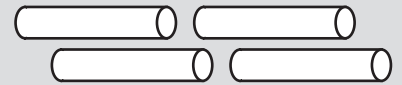

ACCESSORIES

Press Plates - 2
Accessory only -
Not needed for assembly

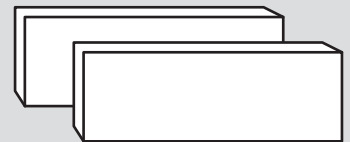

TOOLS NEEDED

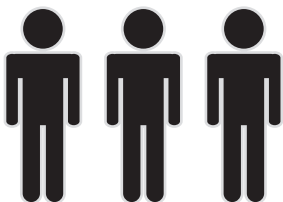

3/4" socket w/ extension



9/16" wrench



YOU WILL NEED A FORKLIFT AND AT LEAST 3 PEOPLE TO PROPERLY ASSEMBLE THIS PRESS. OPERATION OF THE FORKLIFT SHOULD BE PERFORMED BY A LICENSED PROFESSIONAL ONLY. BE SURE TO USE EXTREME CAUTION WHEN ASSEMBLING THIS PRESS, AS YOUR SAFETY IS TOP PRIORITY.

Examine box contents, then proceed with the following instructions.

RAM ASSEMBLY INSTRUCTIONS

1

Forklift located behind press

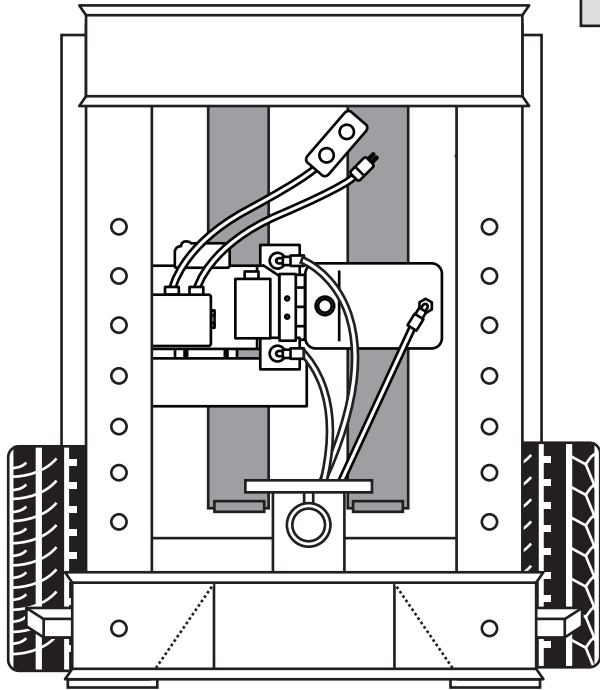

⚠ WARNING

The press must be on a hard, flat surface, bolted to the floor if necessary in the position in which it will remain for the life of the equipment.

Begin behind the press. Using a forklift, place the pump on the back side of the forks, closest to the mast as shown in the diagrams.

- The ram should be upside down with the gauge facing toward the press.
- All hoses should be between the forks.

Note: Handle ram carefully to avoid damage to gauge or gauge face. Do not disconnect hoses prior to assembly.

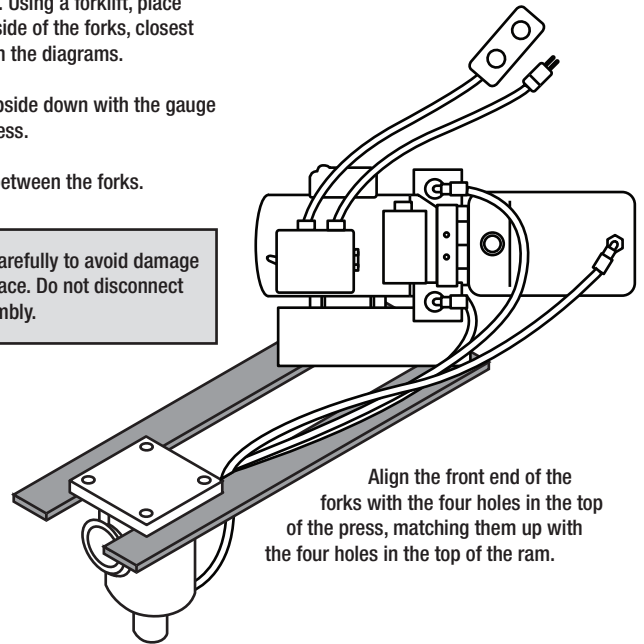

Align the front end of the forks with the four holes in the top of the press, matching them up with the four holes in the top of the ram.

2

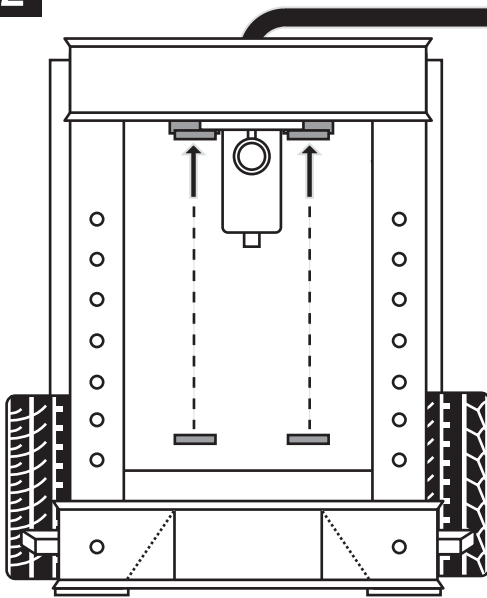

Top of press, looking down and inside

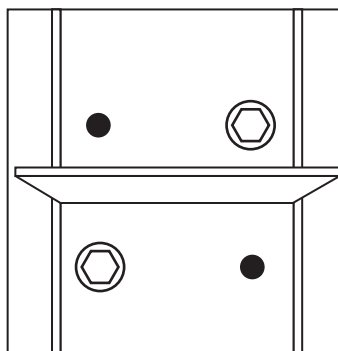

TO BOLT RAM TO PRESS, stand on a sturdy ladder and look down into press from the top. Use the provided 1/2-13 x 3/4" hex head bolts and washers, offsetting the first two bolts and washers for more precise alignment. Finish with the other two bolts and washers until the ram is completely secured to the press frame. *These four bolts will thread directly into pre-tapped holes in the ram.*

Slowly move the forks up toward the top of the press, making sure the holes in the top of the ram are aligned with the holes in the press. The pump assembly will still be resting on the forks.

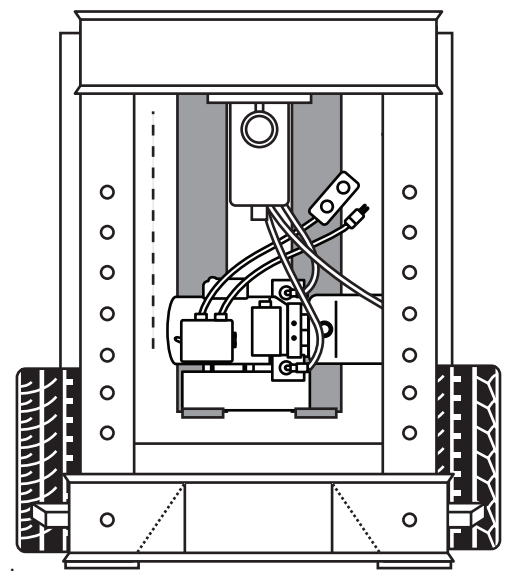

Slowly move the forks back down toward the bottom of the press, leaving the ram securely attached at the top. Stop about mid-way down to easily remove and place the pump assembly.

PUMP ASSEMBLY INSTRUCTIONS

3

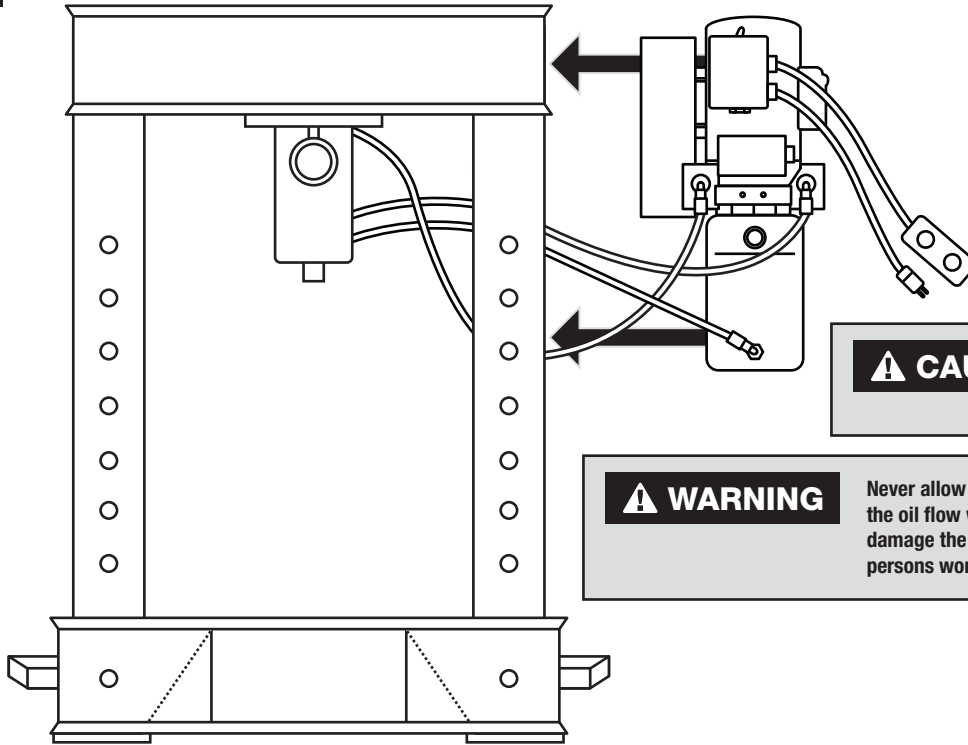

Using at least two people, lift the pump assembly off of the forklift and orient the pump so that the plastic tank is on the bottom. Align with holes on right side of press frame.

Using the 1/2"-13 x 1-1/8" hex head bolts, nuts and washers provided, attach the pump assembly to the press frame. (Line up a bolt and a washer in the inside of the frame first. Finish with the nut attached under the pump assembly. Repeat with other hole.)

CAUTION

All hoses should run **BEHIND** press frame and should be free of kinks, twists or bends.

WARNING

Never allow hoses to kink, twist, curl or bend so tightly that the oil flow within the hose is blocked or reduced. This could damage the hose and possibly result in serious injury to persons working in the immediate vicinity.

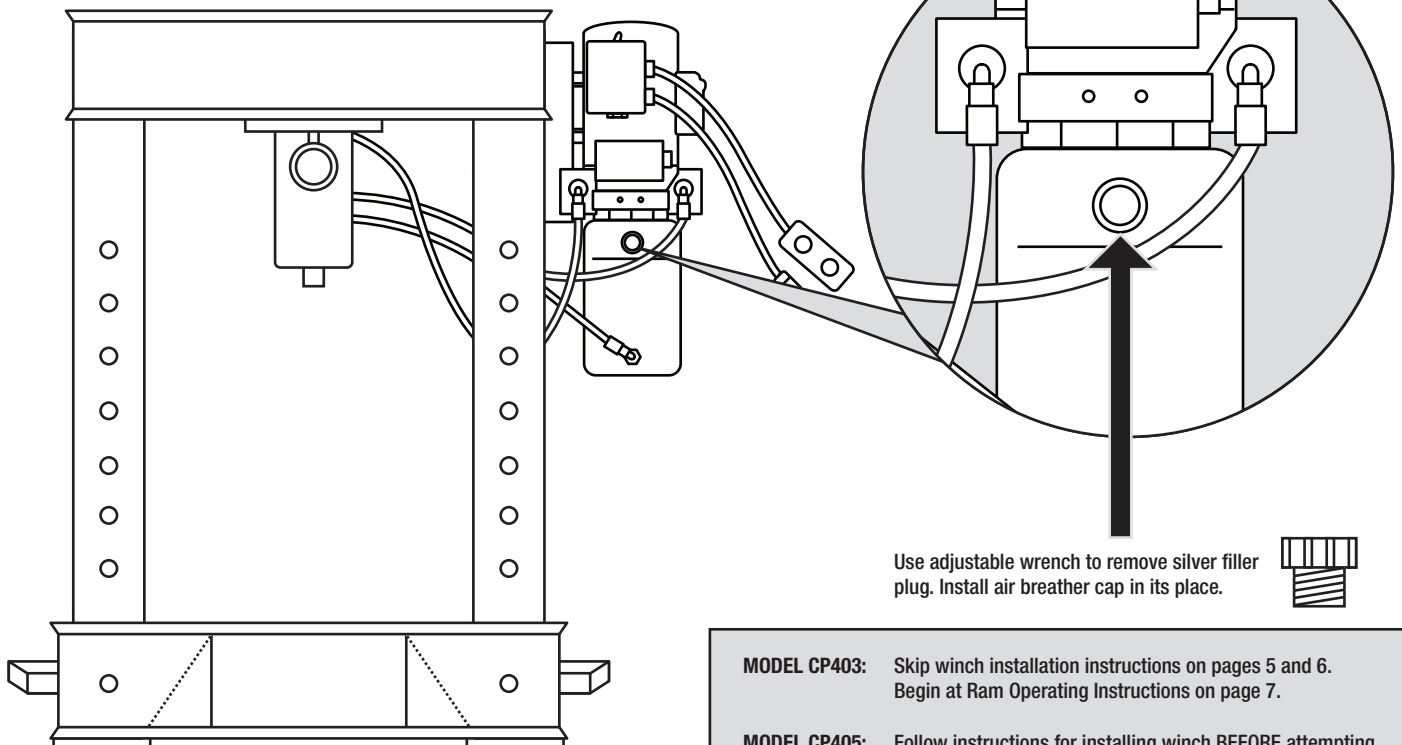

Use adjustable wrench to remove silver filler plug. Install air breather cap in its place.







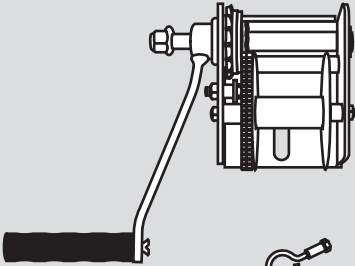

MODEL CP403: Skip winch installation instructions on pages 5 and 6. Begin at Ram Operating Instructions on page 7.

MODEL CP405: Follow instructions for installing winch **BEFORE** attempting to operate press.

Note: Winch instructions refer to model CP405 only. Pages 5 and 6 are not applicable to model CP403 as it does not include a winch kit.

WINCH KIT PARTS LIST - CP405 ONLY

Winch - 1		Cable Clamp - 1	
Long Cable - 1		1/2"-13 x 1-1/2" Hex Head Bolts - 2	
Short Cable- 1		1/2" Nuts - 2	
		Washers - 2	

WINCH INSTALLATION INSTRUCTIONS

1

 Dark Gray- Long Cable
 Light Gray- Short Cable

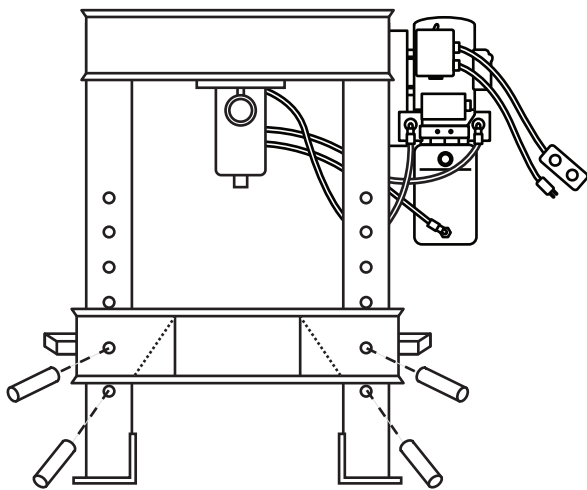

1. Move press bed into LOWEST position and insert all 4 press pins.

Right side of press,
under pump assembly

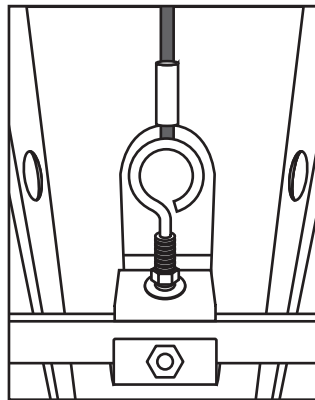

2. Install pre-attached eye bolt on LONGER cable to press bed handle located *under pump assembly*. DO NOT FULLY TIGHTEN. Center with side of press bed and make sure there is enough room to lower or raise both nuts on eye bolt for precise alignment.

Right side of press

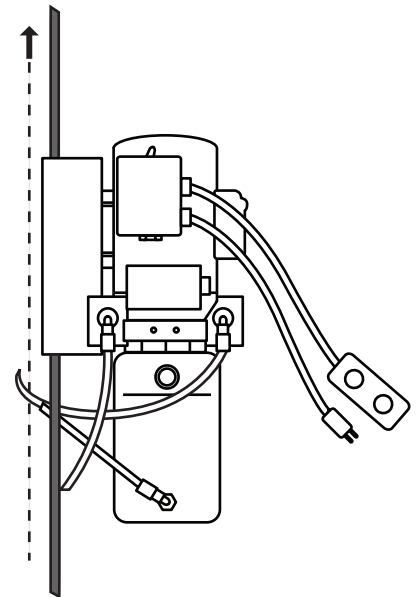

3. Thread the BARE end of the LONGER of the two steel cables up and through the pump assembly.

⚠ WARNING

ALL FOUR (4) pins must be COMPLETELY through to BOTH SIDES of frame in order to operate press.

⚠ WARNING

DO NOT FULLY TIGHTEN.

Note: Refer to manual from winch manufacturer for detailed instructions on winch assembly and cable threading procedure.

WINCH INSTALLATION INSTRUCTIONS

2

LONG CABLE top view of press

WARNING

Mount winch to frame
AFTER threading cable.

This end feeds into winch.



4. Run the long cable up and OVER BOTH ROLLER BRACKETS and feed into winch. Be sure and thread 12 inches (1 foot) of extra cable through winch.

5. Once winch cable has been threaded, pull excess cable back through winch as shown in diagram above. The cable should be locked tightly around itself with no excess cable left hanging. Operate winch enough to remove slack from longer cable.

6. Mount winch to frame using the provided washers, 1/2" nuts and 1/2"-13 x 1-1/2" bolts.

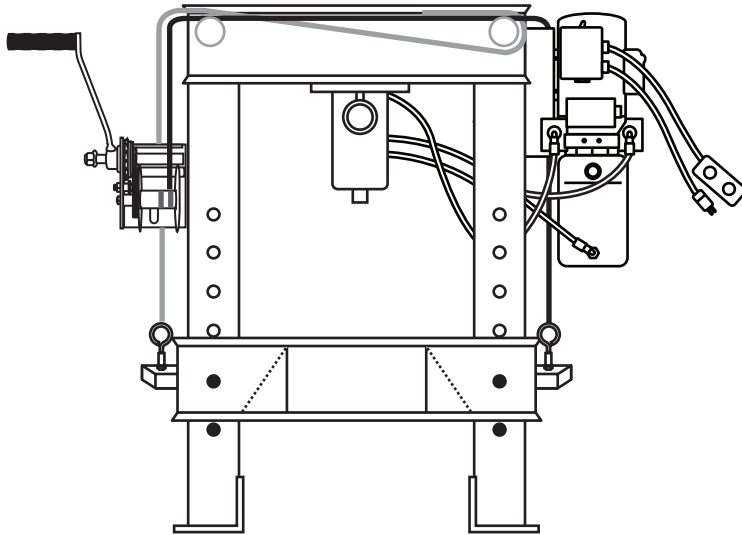
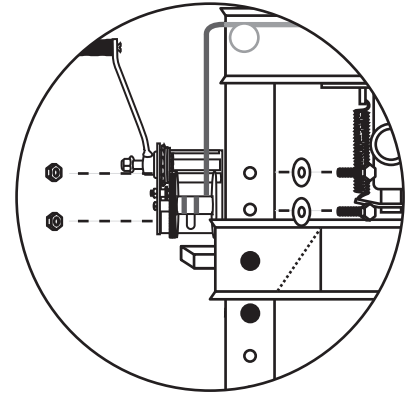
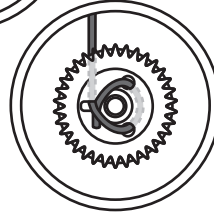
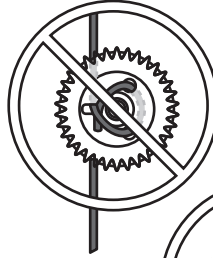

Top view of press with bed in lowest position

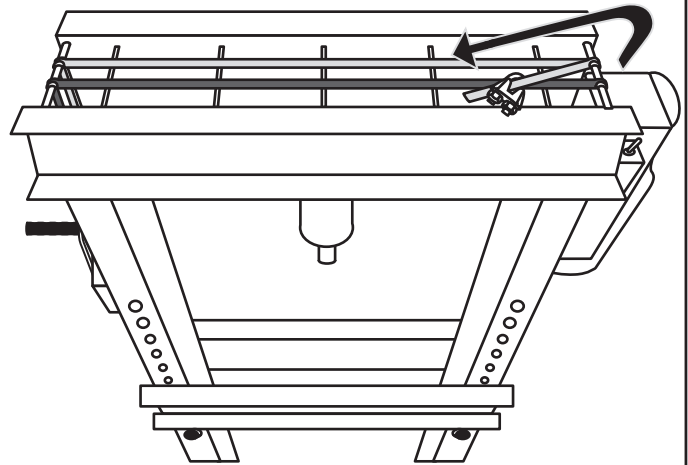

7. Feed the short cable by running it up and OVER first roller, then UNDER second roller. Loop the short cable back toward the winch and securely attach to the longer cable using the cable clamp. Remove slack from short cable before securing to long cable. Clamp should be NO LESS THAN ONE INCH (1") from roller.

Left side of press, under winch

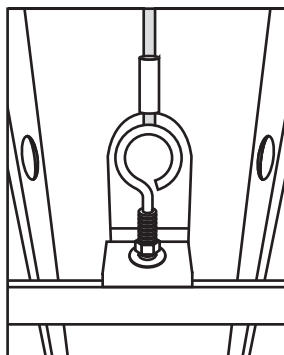

8. Install pre-attached eye bolt on SHORTER cable to press bed handle located under winch after feeding it around in step 7.
9. Turn eye hooks to adjust and level press bed. Once bed is level, firmly tighten eye hook mounting hardware. The steel cable will stretch with use. It may be necessary to repeat this leveling procedure in the future.
10. Test the winch kit by raising and lowering the press bed from its lowest to highest position. Repeat and adjust until bed is level and moves freely throughout its entire range of motion. Cut excess cable when all adjustments are complete.

We want to know if you have any problems with our products. If you are missing any parts or find any damages, call Arcan direct, and we will remedy the situation. Please do not call the store where you purchased this product.

Phone: (800) 879-7316
Email: arcanusa@bellsouth.net

RAM OPERATING INSTRUCTIONS

1. Check to ensure all connections are secure and all bolts and nuts are tightened.
2. Place press plates DIRECTLY under ram, on press bed. ALWAYS center load and press blocks.
2. Plug in the pump assembly.
3. Flip switch on top of pump assembly.
4. Use remote to operate ram.
5. Pump should now operate normally. Repeat steps 1-4 if necessary.

Call Arcan direct at 1-800-879-7316 for any questions regarding the steps listed above.

Note: Sometimes the ram moves in the opposite direction of the arrows on the remote. Do not be alarmed if this happens, as it is commonplace in the initial wiring. Make a note if this does occur. You may reverse your hydraulic lines on either pump or ram. Move the ram up and down accordingly.

Note: The remote control is magnetic and will stick to the steel press frame when not in use.

⚠ WARNING

Do not allow the ram to extend more than 6.125" (6-1/8").

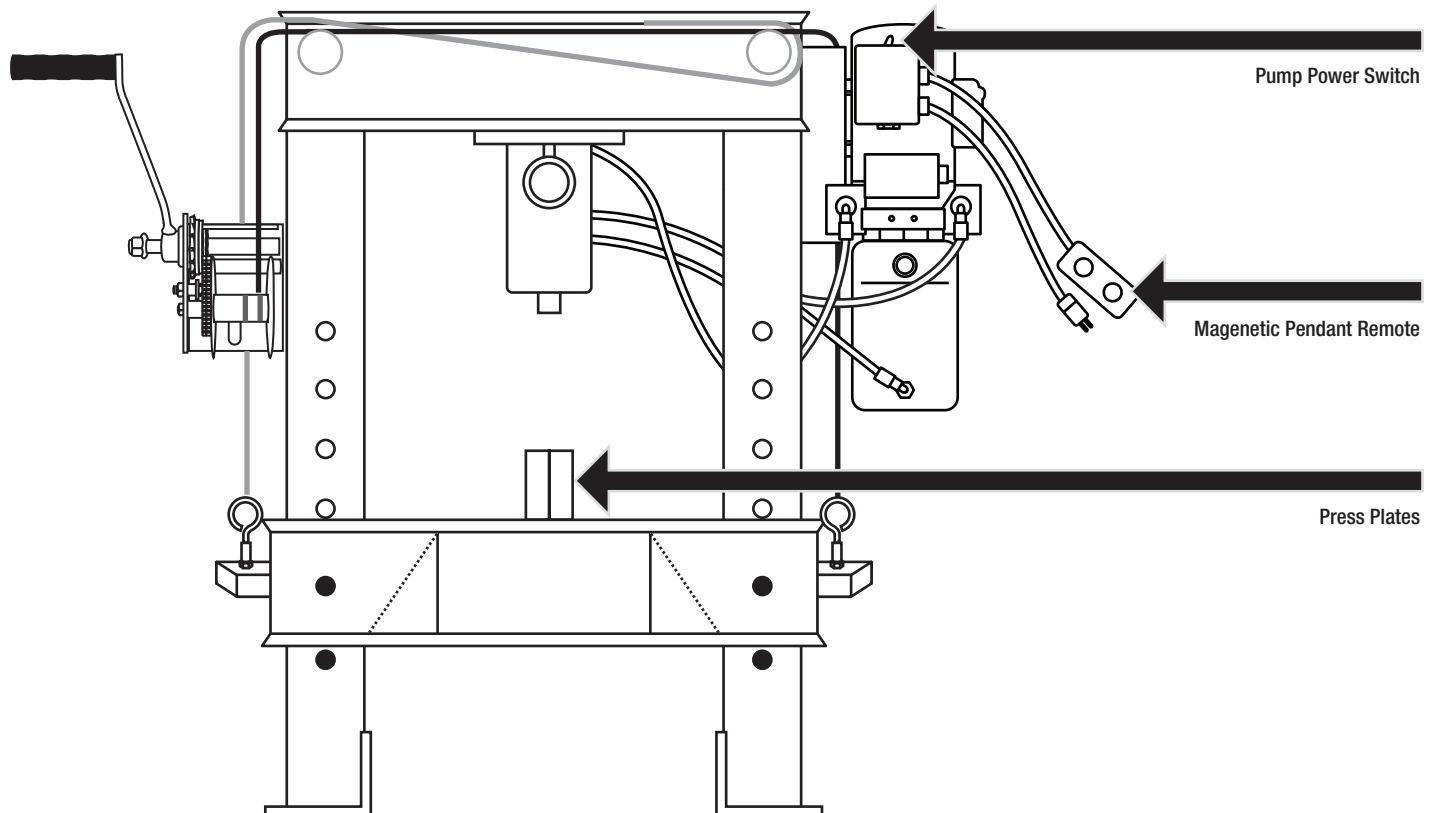

Line drawing representative of model CP405. Winch and winch kit parts are not included with model CP403.

REPLACEMENT PARTS LIST

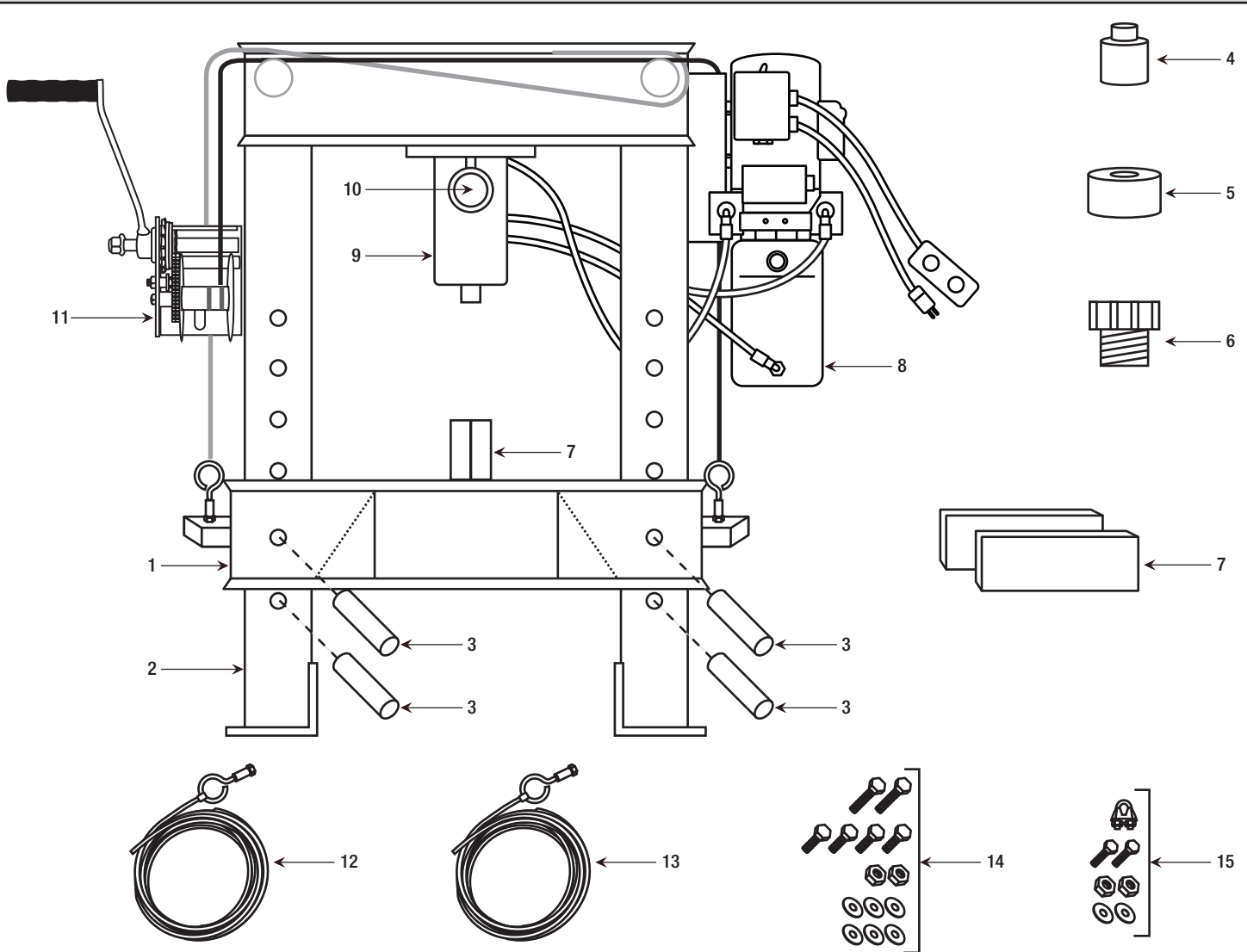

ITEM NO.	ARCAN PART NO.	DESCRIPTION	QTY.	ITEM NO.	ARCAN PART NO.	DESCRIPTION	QTY.
1	* CP40301	Press Bed	1	11	RS50EPPW	Winch (CP405)	1
2	* CP40302	Press Frame	1	12	RS50EPPSC	Short Cable (includes eye bolts) (CP405)	1
3	RSCBP1225	Press Pin	4	13	RS50EPPLC	Long Cable (CP405)	1
4	RS310012	Pushing Adapter	1	14	RS40MPPHK	Press Hardware Kit	1 set
5	RSBS1	Bearing Shield	1			1/2"-13 x 1-1/8" Hex Head Bolt	2
6	RS4050ABC	Air Breather Cap	1			1/2"-13 x 3/4" Hex Head Bolt	4
7	RSCBP1205	Press Plate	2			1/2" Nut	2
8	RS40EPPP	Pump (CP403)	1			Washer	6
	RS50EPPP	Pump (CP405)	1	15	RSWHK	Winch Hardware Kit (CP405)	1 set
9	RS40EPPR	Ram (CP403)	1			Cable Clamp	1
	RS50EPPR	Ram (CP405)	1			1/2"-13 x 1-1/2" Hex Head Bolt	2
10	RS40EPPG	Gauge (CP403)	1			1/2" Nut	2
	RS50EPPG	Gauge (CP405)	1			Washer	2

Items identified with a star (*) are not available separately.

Line drawing representative of model CP405. Winch and winch kit parts are not included with model CP403.

