

OPERATING MANUAL



THIS OPERATING MANUAL CONTAINS IMPORTANT SAFETY INFORMATION. READ CAREFULLY AND UNDERSTAND ALL INFORMATION BEFORE OPERATING THIS TOOL. SAVE THIS MANUAL FOR FUTURE USE.

PARTS LIST

Examine box contents, then proceed with the following instructions.

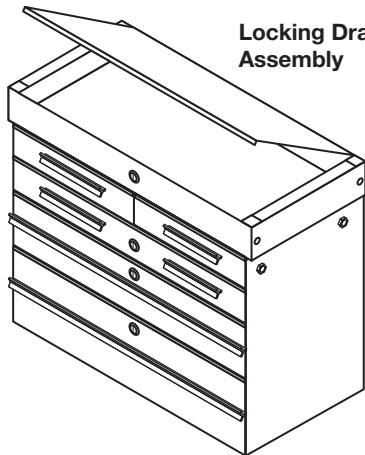

Locking Drawer Assembly

Chrome Legs

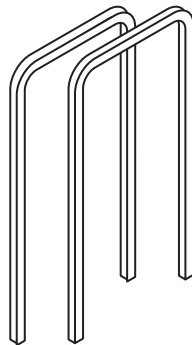

Non-Locking Casters (2)

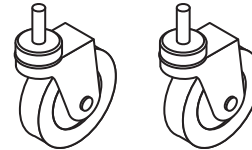

Locking Casters (2)

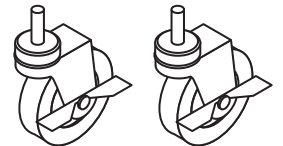

Long Drawer Handle (2)

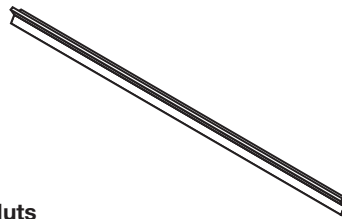

Short Drawer Handles (4)



Bottom Tray

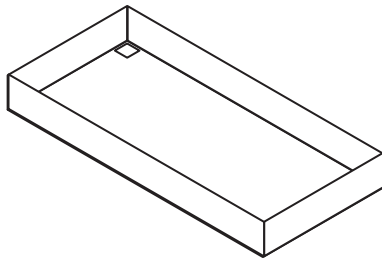

M6x40 Bolts, Washers, & Nuts
(8 Pcs. Bolts and Nuts, 16 Washers)



Drawer Handle Screws (20)



Pry Bar Holder

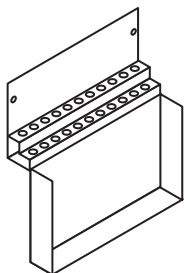

Keys
(Attached to Legs)

Liners

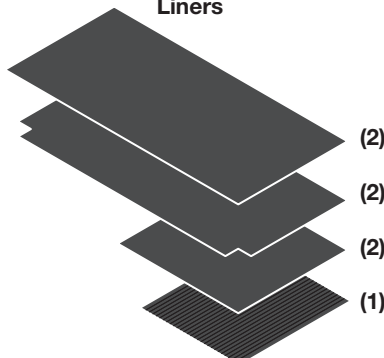

Side Work Bench

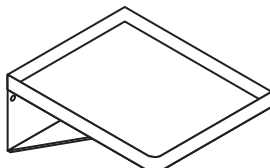

TOOLS NEEDED



Rubber Mallet



Phillips Head
Screwdriver



10mm Wrench



Table or Workbench



2 People

ASSEMBLY INSTRUCTIONS



NOTE

Do not fully tighten fasteners until prompted.

Step 1: Assembly preparation.

Clear table top and set Locking Drawer Assembly on table top, with lid facing up. Position the Locking Drawer Assembly so that one end hangs off of the table enough to allow the chrome legs to go through the square holes. Insert one set of chrome legs through the overhanging holes as shown in Figure 1. Do not bolt legs to top.

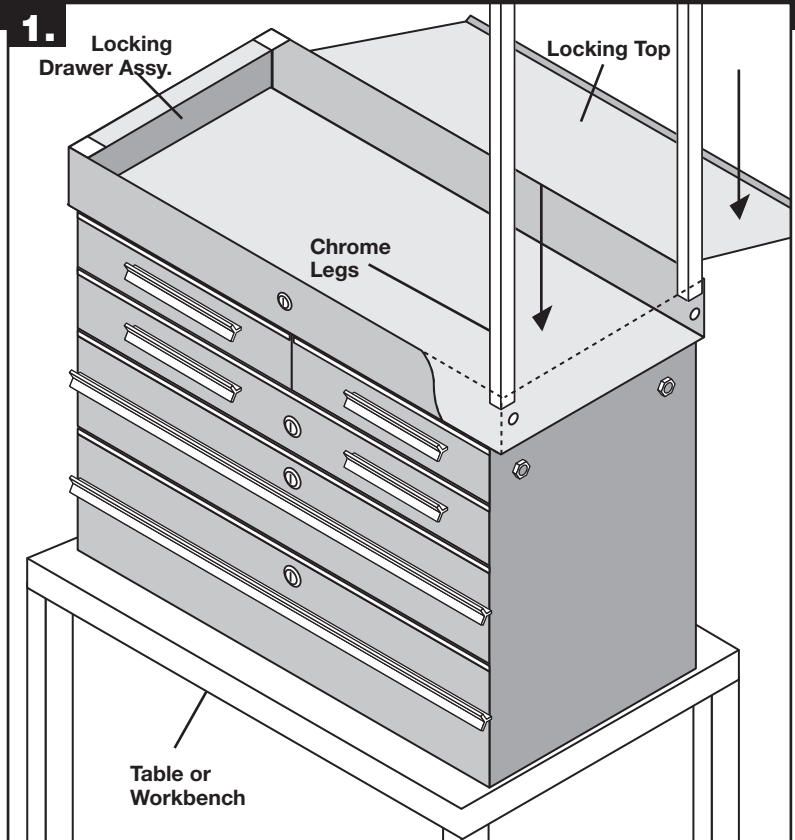

Step 2: Connecting legs and side accessory to drawer assembly

Choose one of the side accessories (Pry Bar Holder or Side Work Bench - Figure 2 shows Pry Bar Holder) for attachment to the overhanging end of the service cart. Align the outermost bolt holes in the accessory with the bolt holes in the end of the cart and with the uppermost holes in the chrome legs. Position a washer and insert an M6x40 bolt through the washer, bolt holes, and legs as shown. Secure bolts with a flat washer, lock washer, and nut on inside of Locking Drawer Assembly. Tighten bolts until parts fit together firmly.

Repeat steps 1 and 2 for other end of cart, using remaining side accessory.

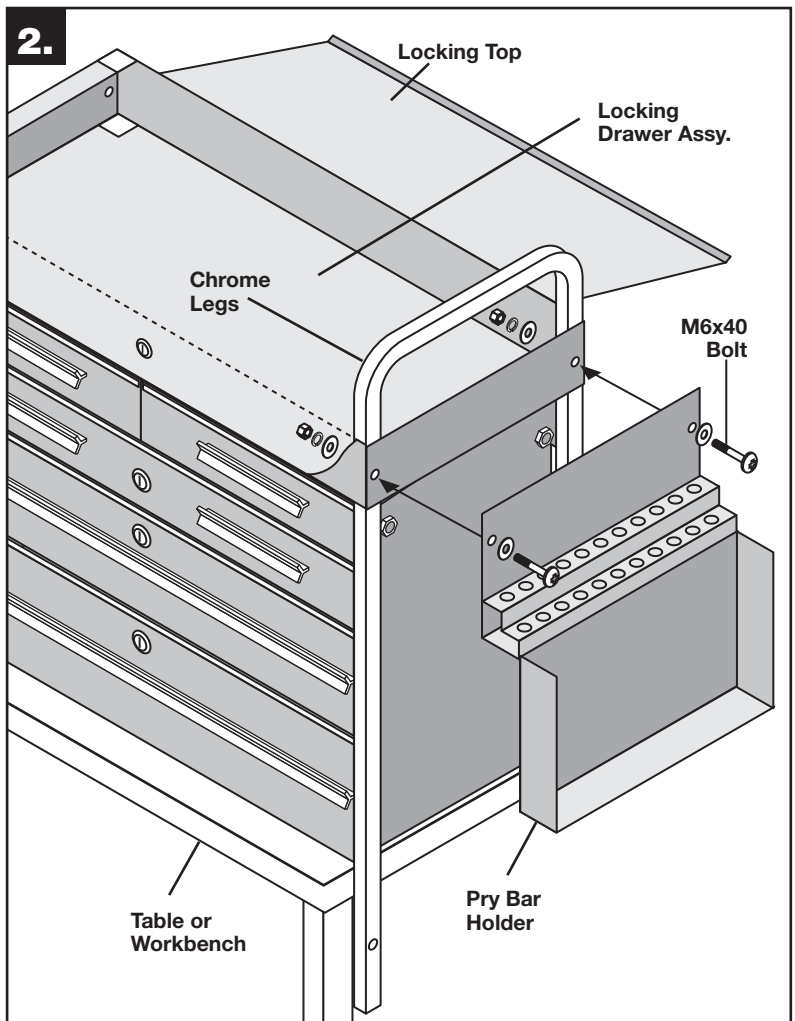

ASSEMBLY INSTRUCTIONS

Step 3: Connecting the bottom tray to the chrome legs.

Lift the cart and place on top of the bottom tray with chrome legs through the square leg-holes. Align bolt holes in bottom tray with lower holes in legs and insert an M6x40 bolt through the washer, bolt holes, and legs as shown. Repeat with all remaining holes in bottom tray.

Step 4: IMPORTANT: Tighten all bolts.

At this point, all bolts should be tightened. Tighten bolts opposite each other rather than tightening all bolts on one side first so that cart remains aligned. Avoid using excessive force when tightening bolts. Over-tightening bolts can make drawers bind and hinder their operation.

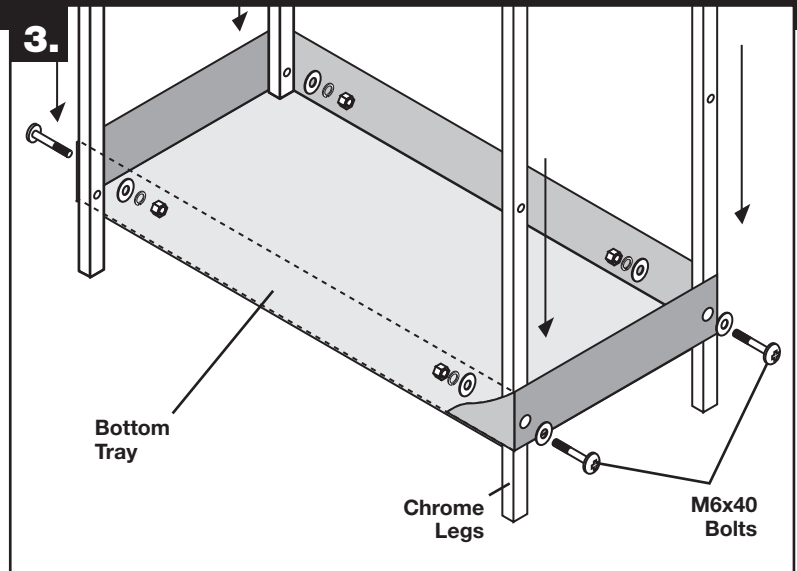

Step 5: Attaching casters.

With the provided keys, lock all drawers, the top, and the Pry Bar Holder to prevent them from opening. Turn the cart upside down, allowing it to rest on chrome leg tops with the plastic inserts facing up.

NOTE

Do not allow the Side Work Bench to swing freely, as it may be damaged or cause injury as cart is turned upside down.

Insert the stem of one caster into the hole in a plastic insert. Using a rubber mallet, hammer the casters into place until the stem is no longer visible. Repeat with other casters.

NOTE

Ensure that both locking casters are on same end of the cart.

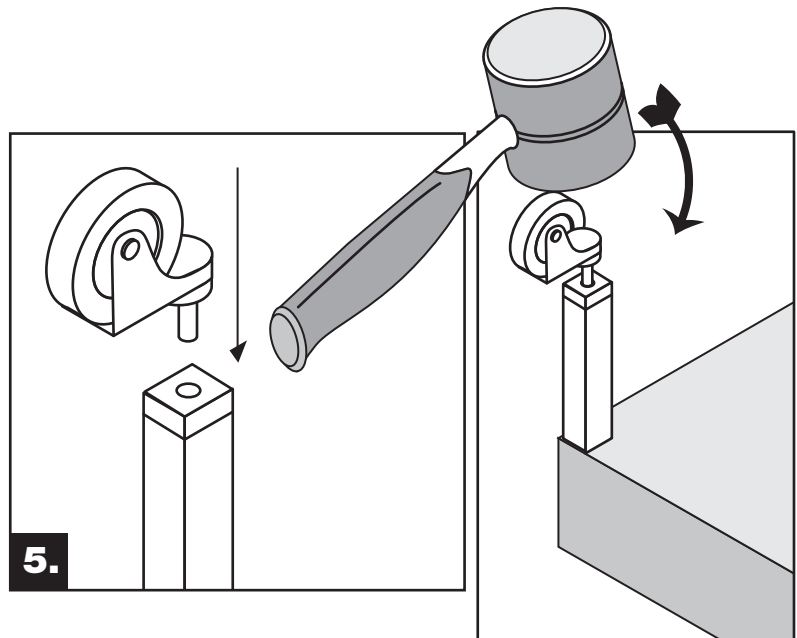

Once casters are installed, stand cart upright. Assembly is complete.

PARTS BREAKDOWN

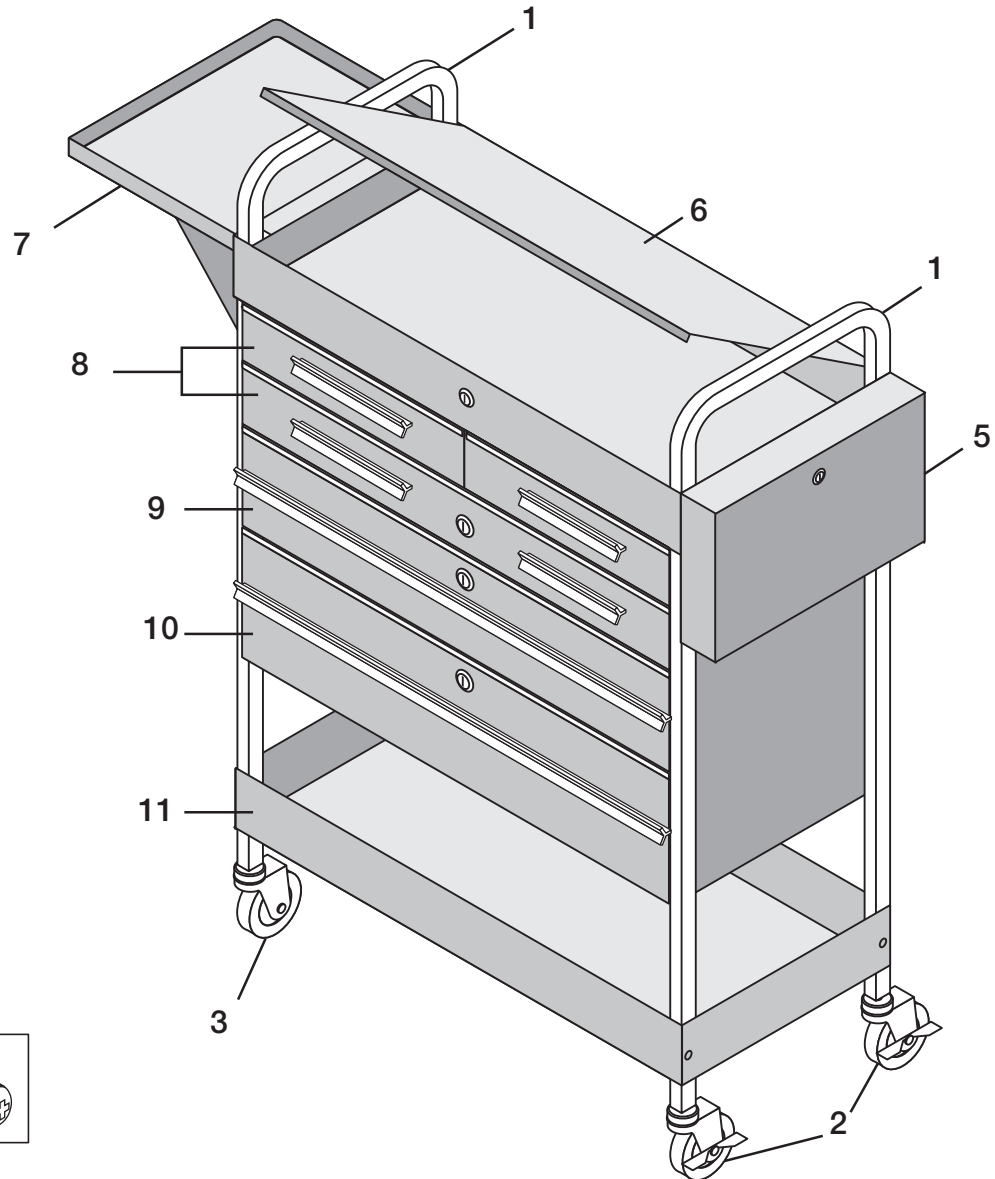

REPLACEMENT PARTS LIST

Item	Part #	# Req'd	Description	Part #	Description
1	RSSC7N	2	Chrome Leg/ea.	Also Available:	
2	RS5LCA	2	Locking Caster/ea.	RSRBSLIDEC2	Clip-On Roller bearing Slide/pr.
3	RS5NLCA	2	Non-Locking Caster/ea.	1110	EVA Foam for Trays/10 PK.
4	RS8045BK	1	Bolt Kit (Incl. 8 M6x40 Bolts with Nuts and 16 Washers)	1111	EVA Foam for Drawers/10 PK.
5	8011	1	Pry Bar Holder	8004SSM	Rubber Liner for Side Shelf/10 PK.
6	8002	1	Top Lid	8045LS	5 Pc. Lock Set, Keyed Alike
7	8004	1	Side Work Station	RSSCPP1	Set of 4 Plastic Inserts
8	8016	1	Replacement 3 Drawer Unit	RS3DHDL	Short Drawer Handle
9	8006RB	1	Replacement Large Drawer	RS8006HDL	Long Drawer Handle
10	8006XRB	1	Replacement X-Large Drawer	RS8006HDLS	Handle Screws (Set of 4)
11	8007	1	Replacement Shelf		

ARCAN PROFESSIONAL TOOLS CUSTOMER SERVICE

1 800-879-7316