

PARTS BREAKDOWN

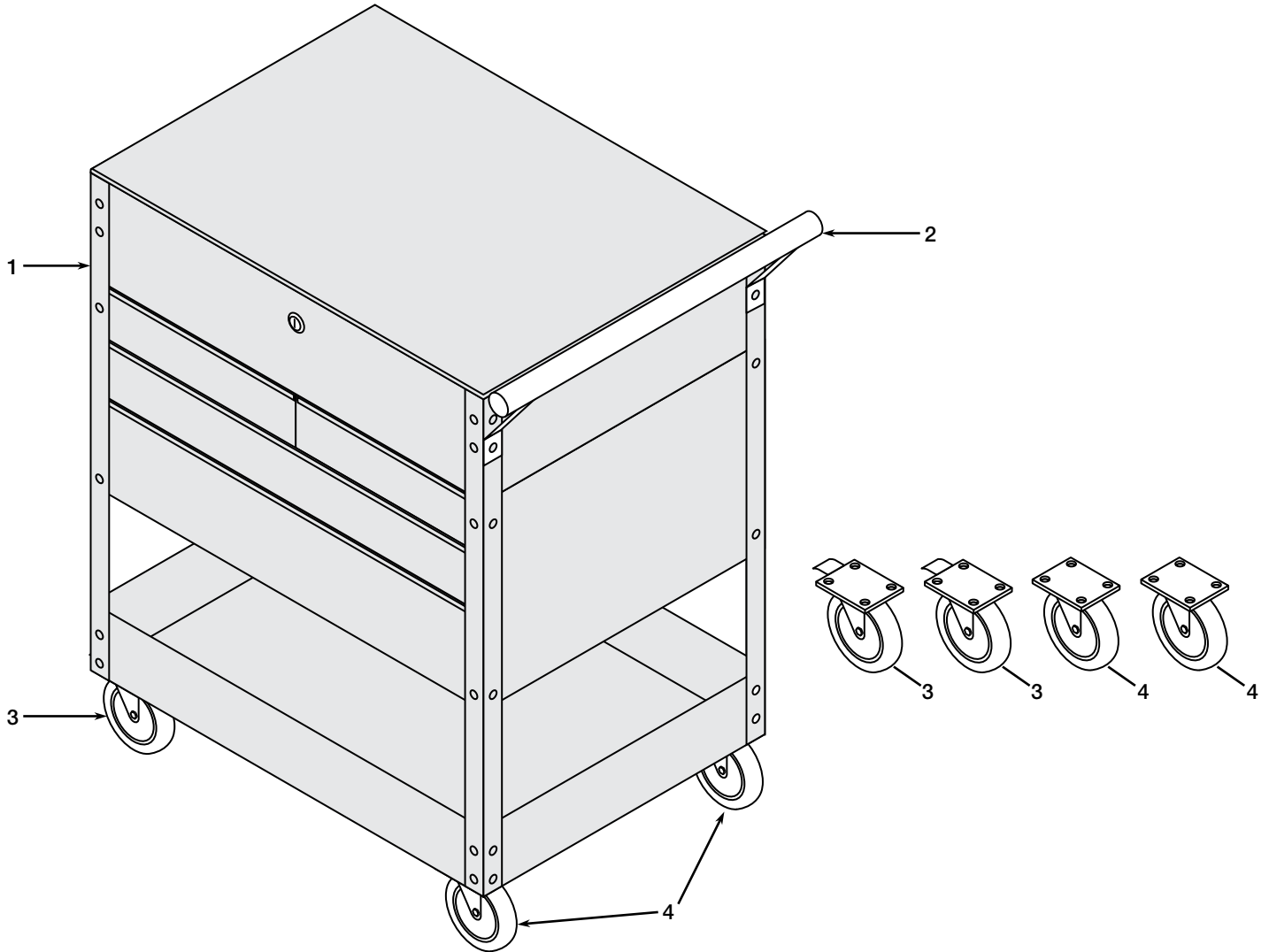

REPLACEMENT PARTS LIST

| Item | Part # | # Req'd | Description |
|------|-----------|---------|------------------------|
| 1 | RS8040SS | 4 | Side Supports/ea. |
| 2 | RS8040PH | 1 | Push Handle/ea. |
| 3 | RS8040LC | 2 | Locking Caster/ea. |
| 4 | RS8040NLC | 2 | Non-Locking Caster/ea. |

Also Available:

| | |
|------------|-------------------------------------------------------------------------------------|
| RS8040LK | Lock with Keys/ea. |
| RS8040CBK | Caster Bolt Kit- (16) ea. (M8x16 Hex Head Bolts, M8 Nuts, & Spring Washers) |
| RS8040HBK | Handle Bolt Kit- (2) ea. (M8x16 Ball Type Screws, M8 Nuts, & Spring Washers) |
| RS8040SSBK | Side Support Bolt Kit- (44) ea. (M8x12 Ball Type Screws, M8 Nuts, & Spring Washers) |

PARTS BREAKDOWN AND OPERATING MANUAL

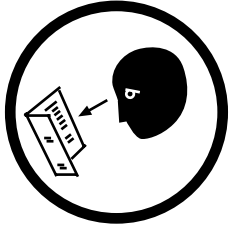

THIS OPERATING MANUAL CONTAINS IMPORTANT SAFETY INFORMATION. READ CAREFULLY AND UNDERSTAND ALL INFORMATION BEFORE OPERATING THIS TOOL. SAVE THIS MANUAL FOR FUTURE USE.

PARTS LIST

Examine box contents, then proceed with the following instructions.

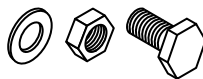
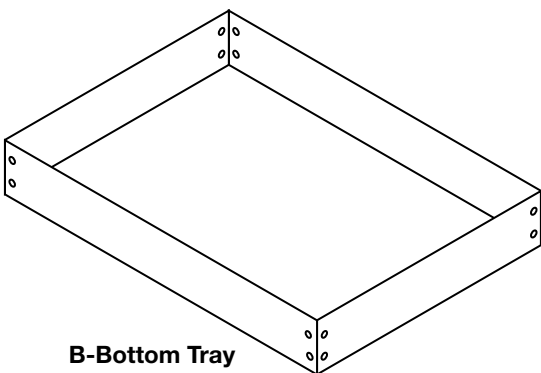
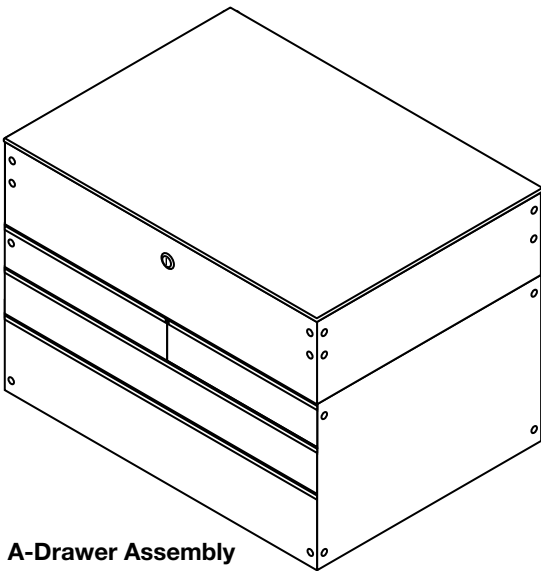

C-Caster Bolt Kit (16) ea:
M8x16mm Bolt
M8 Nut
Spring Washers

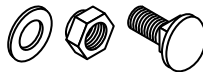

D-Side Support Bolt Kit (44) ea:
M8x12mm Ball Type Screws
M8 Nuts
Spring Washers

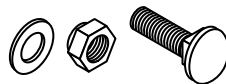

E-Handle Bolt Kit (2) ea:
M8x16mm Ball Type Screws
M8 Nuts
Spring Washers

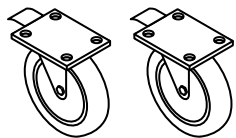

F-Locking Casters (2)

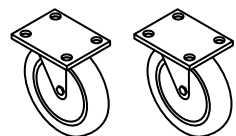

G-Non-Locking Casters (2)

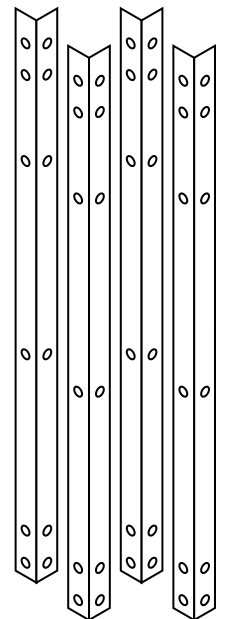

I-Side Supports (4)

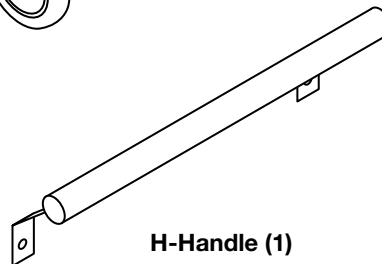

H-Handle (1)



J-Keys
(Attached to
Drawer Lock)

TOOLS NEEDED



Tabletop or
workbench*



2 People



13mm Wrench



Ratchet with
13 mm socket



Adjustable
Wrench

ASSEMBLY INSTRUCTIONS

Step 1: Assembly Preparation

Remove all contents from box. Reference the parts list to make sure you have all the parts.

Verify your tabletop or workbench can support 150 lbs. (68 kg.).

CAUTION Failure to follow this warning could result in damage to property or personal injury.

NOTE Cover table or workbench to prevent any damage to surface.

Step 2: Attaching Casters

Turn bottom tray (B) upside down. Align holes in locking and non-locking casters (F & G) with matching holes in the bottom tray as shown in figure 2.a. Attach washers, lock washer and nuts from caster bolt kit (C) and hand tighten.

NOTE: Ensure that both locking casters are on same end of the cart.

Step 3: Aligning the Side Supports

Make sure the drawer assembly lid is open. Place two of the four side supports (I) face up on table as shown in figure 3. Place drawer assembly (A) and bottom tray (B) on supports as shown in figure 3 and align with matching holes in side supports.

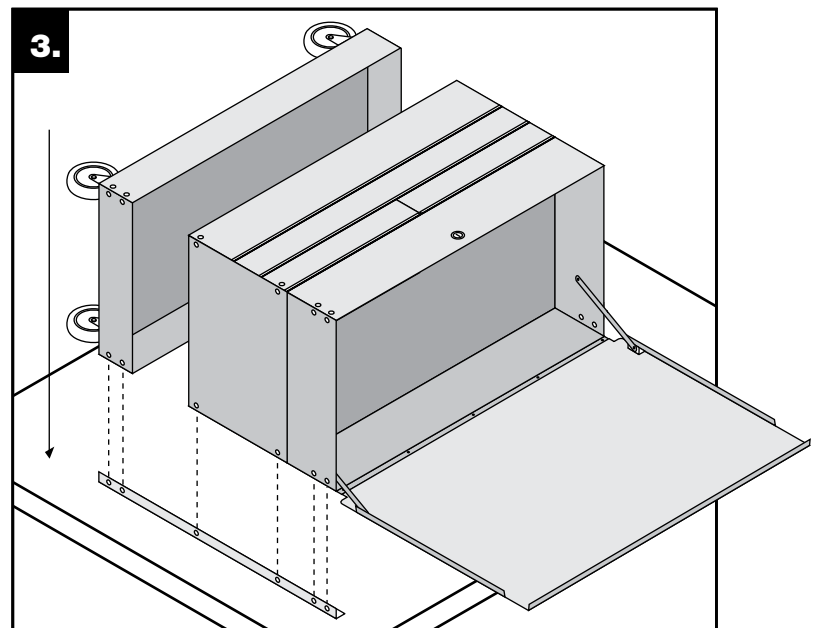
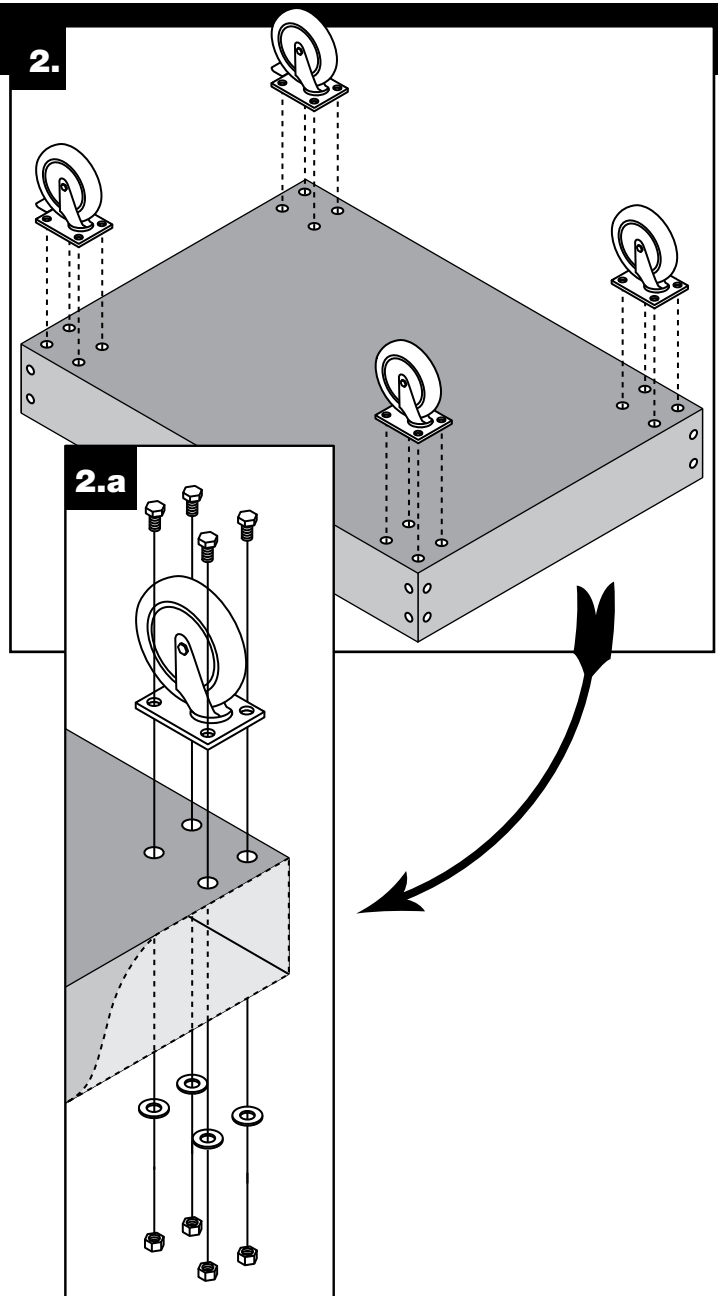

ASSEMBLY INSTRUCTIONS

Step 4: Attaching the Handles

Align the other two side supports (I) with the front corners of the bottom tray and drawer assembly and let them rest on top as shown in figure 4. Align the hole on the handle (H) with the second hole down on the drawer assembly and (un-attached) side support as shown in figure 4. Insert handle bolts (E) through handle, through the side support, and into the drawer assembly as shown in figure 4. Secure with washer and nut from handle bolt kit (E) and hand tighten.

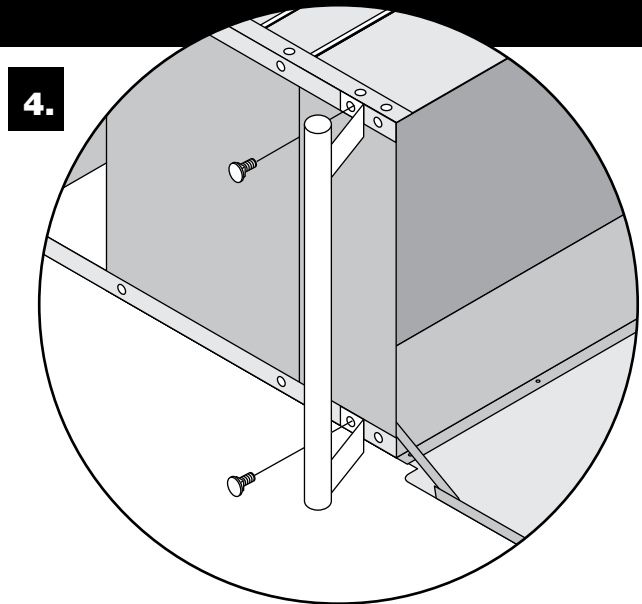

Step 5: Attaching Bottom Tray and Drawer Assembly to Side Supports

Once handle is attached, align holes in side supports (I) with matching holes in bottom tray (A) and drawer assembly (B) as shown in figure 5. Insert side support bolts (D) through side supports and into bottom tray and/or drawer assembly and secure from the inside with side support washers and nuts until all side holes have been attached and hand tightened.

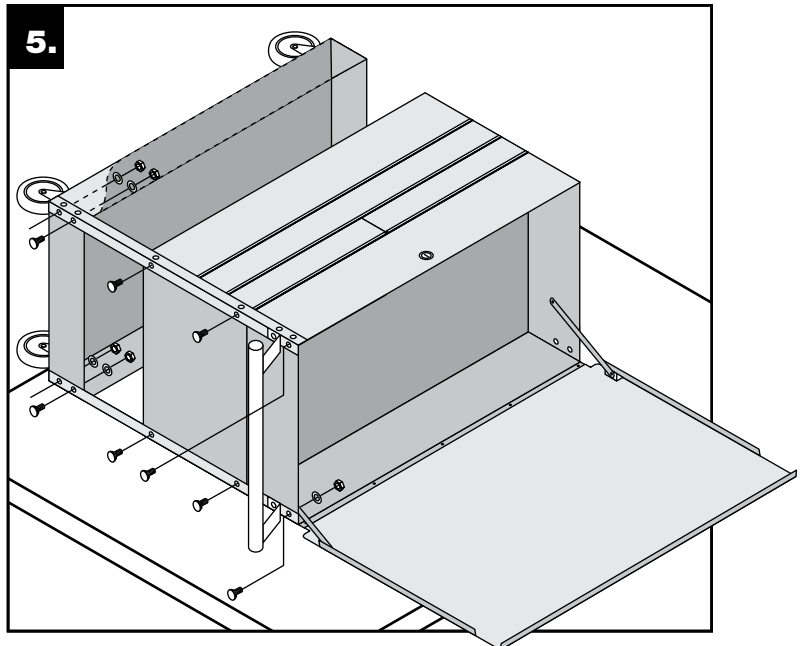

Step 6: Securing Side Supports

Using two people, turn the cart upright. Continue to bolt through aligned holes in the front and back of the cart with the side support bolts, washers, and nuts (D) as shown in figure 6. Hand tighten. ALL holes should now be aligned and secured.

Step 7: Tightening Bolts

Use a 13mm wrench and ratchet with 13mm socket or adjustable wrench to tighten all bolts. Once all bolts are tightened, your cart is complete. See page 4 for parts breakdown.

