

### PARTS BREAKDOWN

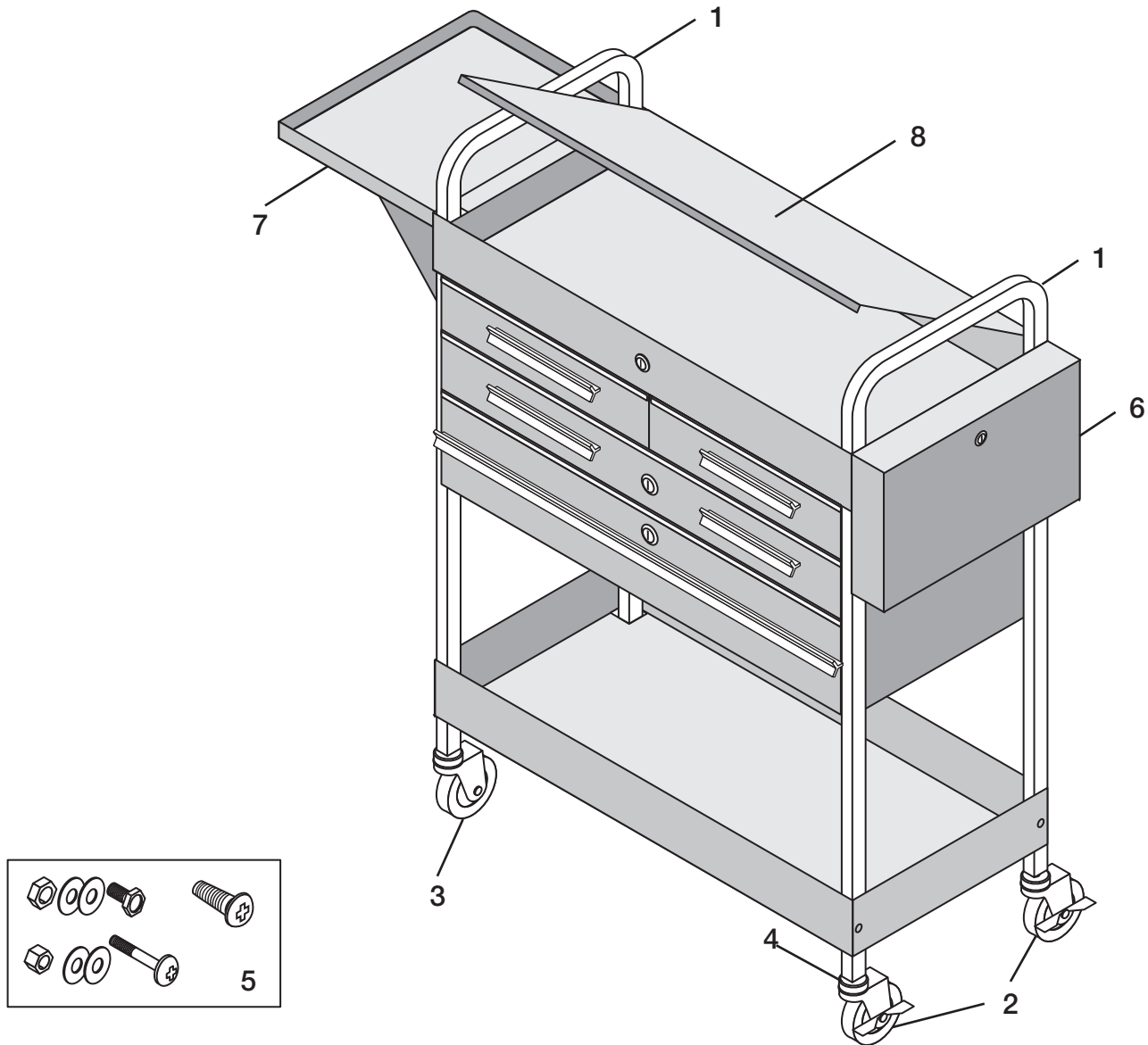

### REPLACEMENT PARTS LIST

Item	Part #	# Req'd	Description
1	*	2	Chrome Leg/ea.
2	RSSCPLW	2	Locking Caster/ea.
3	RSSCPW	2	Non-Locking Caster/ea.
4	RSSCPP1	1	Set of 4 Plastic Inserts
5	RSSCPHK	1	Bolt Kit (Incl. 8 ea. of 10mm and 14mm bolts, nuts, washers and 4 screws)
6	8011	1	Pry Bar Holder
7	8004	1	Side Work Station
8	8002	1	Top Lid

### ALSO AVAILABLE

Part #	Description
RS3HDL	Short Drawer Handle
RS8006HDL	Long Drawer Handle
RS8006HDLS	Handle Screws (Set of 4)
RSRBSLIDEC2	Clip-On Roller Bearing Slide/pr.
8006	Replacement Large Drawer
8016	Replacement 3 Drawer Unit
8007	Replacement Third Shelf
8013LS	4-Piece Lock & Key Set, Keyed Alike
1110	EVA Foam for Trays / 10-pk.
1111	EVA Foam for Drawers / 10-pk.
8004SSM	Rubber Liner for Side Shelf / 10-pk.

\* For replacement, purchase RSSC7, Chrome Leg, and 8014, Leg Extensions.

ARCAN PROFESSIONAL TOOLS CUSTOMER SERVICE

1 800-879-7316

## OPERATING MANUAL

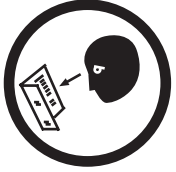

**THIS OPERATING MANUAL CONTAINS IMPORTANT SAFETY INFORMATION. READ CAREFULLY AND UNDERSTAND ALL INFORMATION BEFORE OPERATING THIS TOOL. SAVE THIS MANUAL FOR FUTURE USE.**

© Copyright 2009, Arcan®

## PARTS LIST

Examine box contents, then proceed with the following instructions.

Locking Drawer Assembly

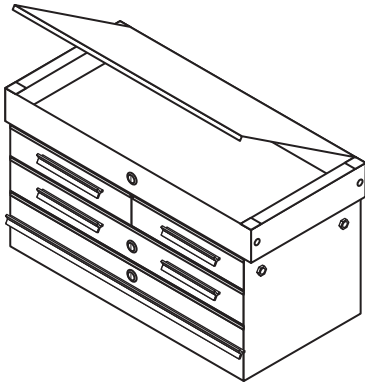

Chrome Legs (2)  
(With Inserts Installed)

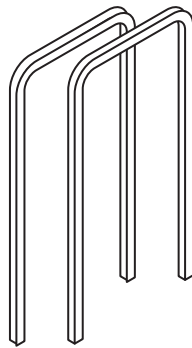

Non-Locking Casters (2)

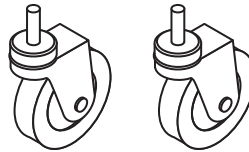

Locking Casters (2)

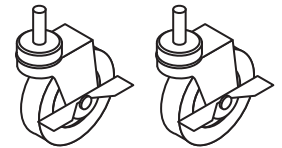

14mm Bolts, Nuts, & Washers  
(8 Pcs. Each)

Bottom Tray

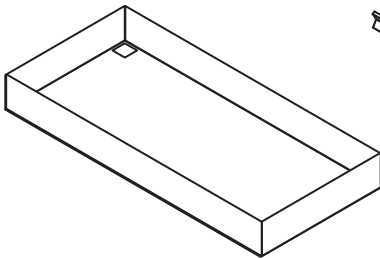

Long Drawer Handle (1)

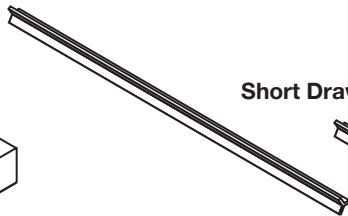

10mm Bolts, Nuts, & Washers  
(8 Pcs. Each)

Short Drawer Handles (4)

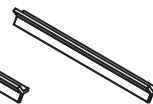

Drawer Handle Screws (14)

Pry Bar Holder

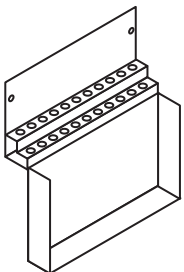

Keys  
(Attached to Legs)

Side Work Bench

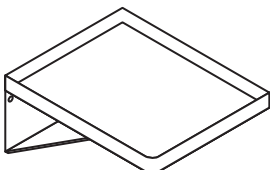

## TOOLS NEEDED



Rubber Mallet



Phillips Head  
Screwdriver



10mm Wrench



Table or Workbench



2 People

# ASSEMBLY INSTRUCTIONS



**NOTE** Do not fully tighten fasteners until prompted.

## Step 1: Assembly preparation.

Clear table top and set Locking Drawer Assembly on table top, with lid facing up. Position the Locking Drawer Assembly so that one end hangs off of the table enough to allow the chrome legs to go through the square holes. Insert one set of chrome legs through the overhanging holes as shown in Figure 1. Do not bolt legs to top.

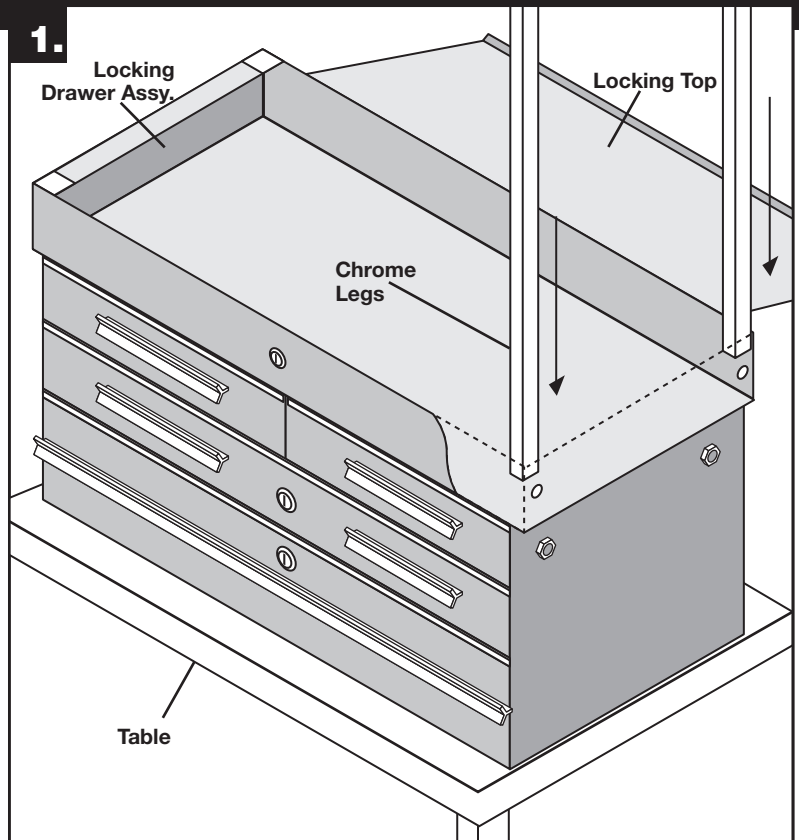

## Step 2: Connecting legs and side accessory to drawer assembly

Choose one of the side accessories (Pry Bar Holder or Side Work Bench - Figure 2 shows Pry Bar Holder) for attachment to the overhanging end of the service cart. Align the outermost bolt holes in the accessory with the bolt holes in the end of the cart and with the uppermost holes the chrome legs. Position a washer and insert a 10mm bolt through the washer, bolt holes, and legs as shown. Secure bolts with a flat washer, lock washer, and nut on inside of Locking Drawer Assembly. Tighten bolts until parts fit together firmly.

Repeat steps 1 and 2 for other end of cart, using remaining side accessory.

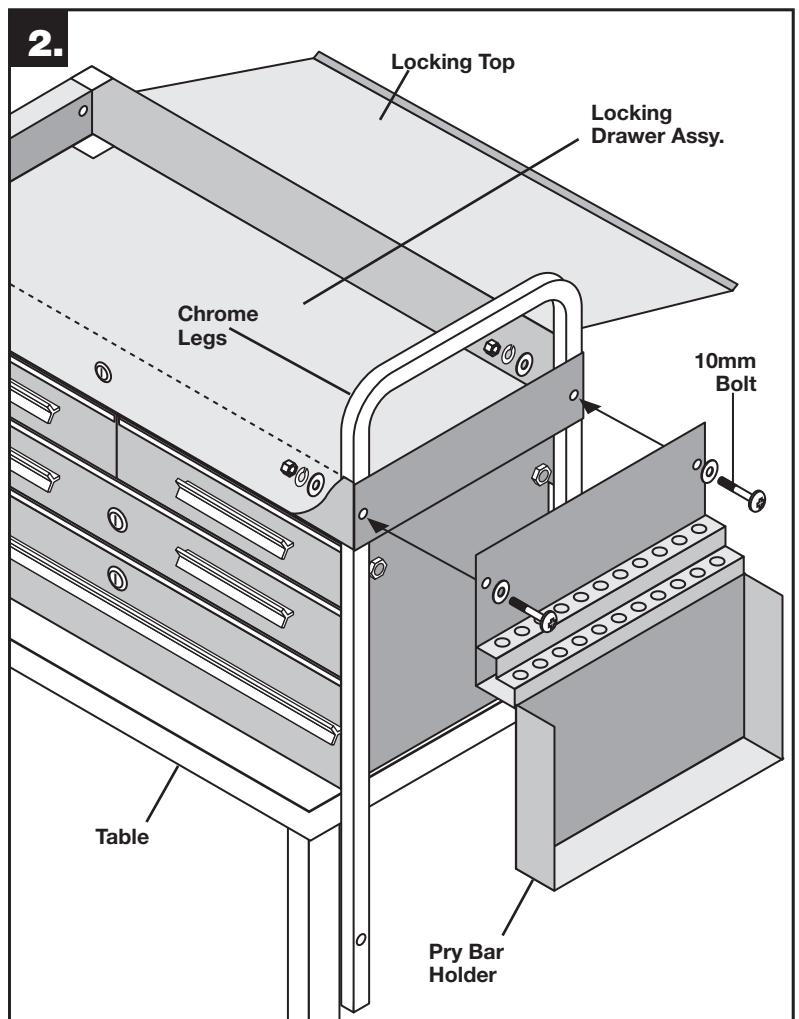

## ASSEMBLY INSTRUCTIONS

### Step 3: Connecting the bottom tray to the chrome legs.

Lift the cart and place on top of the bottom tray with chrome legs through the square leg-holes. Align bolt holes in bottom tray with lower holes in legs and insert a 10mm bolt through the washer, bolt holes, and legs as shown. Repeat with all remaining holes in bottom tray.

### Step 4: IMPORTANT: Tighten all bolts.

At this point, all bolts should be tightened. Tighten bolts opposite each other rather than tightening all bolts on one side first so that cart remains aligned. Avoid using excessive force when tightening bolts. Over-tightening bolts can make drawers bind and hinder their operation.

### Step 5: Attaching handles to drawer faces.

Open the bottom drawer of the service cart. Align the ends of the long handle with the edges of the bottom drawer, so that the channel in the handle covers all four holes in the front of the drawer. Insert screws through each hole from inside the drawer and into the drawer handle channel. Tighten the screws. Repeat for all remaining drawers using short handles.

#### NOTE

Do not allow the handles to overhang the ends of the drawer faces, as they will interfere with the operation of the drawer.

### Step 6: Attaching casters.

With the provided keys, lock all drawers, the top, and the Pry Bar Holder to prevent them from opening. Turn the cart upside down, allowing it to rest on chrome leg tops with the plastic inserts facing up.

#### NOTE

Do not allow the Side Work Bench to swing freely, as it may be damaged or cause injury as cart is turned upside down.

Insert the stem of one caster into the hole in a plastic insert. Using a rubber mallet, hammer the casters into place until the stem is no longer visible. Repeat with other casters.

#### NOTE

Ensure that both locking casters are on same end of the cart.

Once casters are installed, stand cart upright. Assembly is complete.

